

Hydraulic Swivel clamps, double action

Operating pressure max. 250 bar

Hydraulic swivel clamps are particularly designed for applications which require high clamping forces and easy loading of workpieces in confined spaces. The options to order separately the clamping cylinder, clamping arm, pressure spindle, flange and the adaptor allows you to decide what to order according to your needs.

Technical characteristics:

- Screw-in and block version available
- On the screw-in version both A and B ports are on the top flange and at the bottom
- You are free to choose the clamping arm position over 360°
- Glide ring seal with high wear resistance
- Piston with guide ring
- Long piston rod guide
- Swivel direction can be changed by the customer
- Change to linear stroke (without swivel) is possible.
- For block version, sensing of the clamping position is possible

Important note

- Clamping must be accomplished in the vertical stroke range (S2).
- The clamping arm cannot be impeded during swivel
- The cycle time for a clamping or a unclamping stroke should not fall under 1,5 sec. If necessary, the oil flow must be reduced. Observe the max. permitted oil flow.

Recommended accessories (separate order)









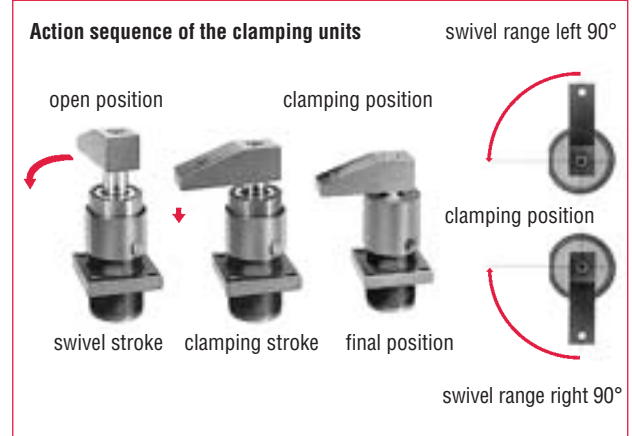
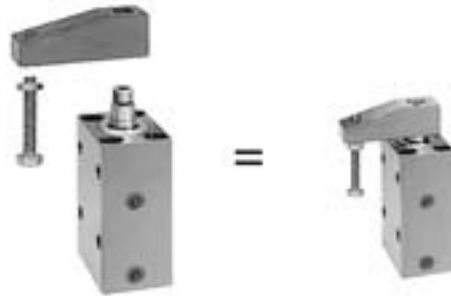





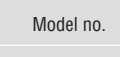

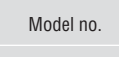
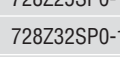
2 straight screw connections D8S-R1/8

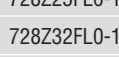
Screw-in version



Block version

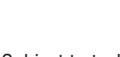

	Basic unit					Set parts (separate order)			
	Model-Nr.		Clamping force at 100 bar [daN]	Volume flow max. [l/min]	Seal kit [daN]	Clamping arm	Adaptor	Flange	Spindle
	Swivel right	Swivel left				Model no.	Model no.	Model no.	Model no.
 Screw-in version	726D25221-2	727D25221-2	197	0,26	720V25-0006	 728Z25SP0-1	 728Z25AD0-1	 728Z25FLO-1	 220203-M
	726D32321-2	727D32321-2	197	0,53	720V32-0006	 728Z32SP0-1	 728Z32AD0-1	 728Z32FLO-1	220203-M
	726D40341-2	727D40341-2	480	0,87	720V40-0006	 728Z40SP0-1	 728Z40AD0-1	 728Z32FLO-1	220203-M
 Block version	726D25222-2	727D25222-2	788	0,26	720V25-0006	 728Z25SP0-2	 728Z25AD0-2	–	220203-M
	726D32322-2	727D32322-2	788	0,53	720V32-0006	 728Z32SP0-2	 728Z32AD0-2	–	220203-M
	726D40342-2	727D40342-2	1232	0,87	720V40-0006	 728Z40SP0-2	 728Z40AD0-2	–	220203-M

Screw-in version

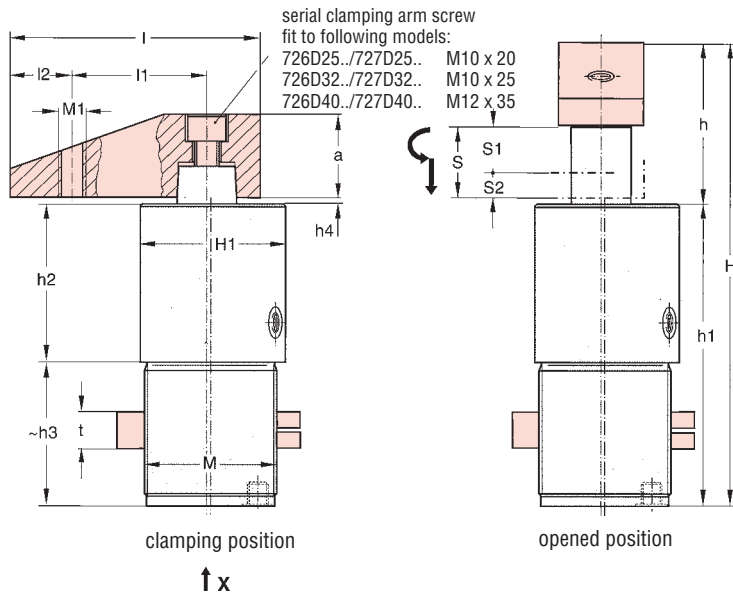

S = complete stroke
S1 = swivel stroke
S2 = clamping stroke

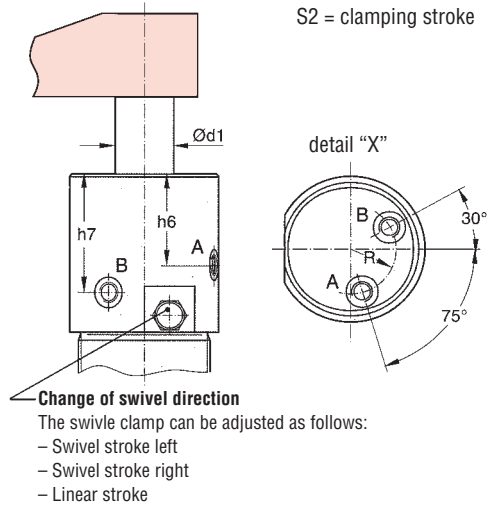

■ = set parts

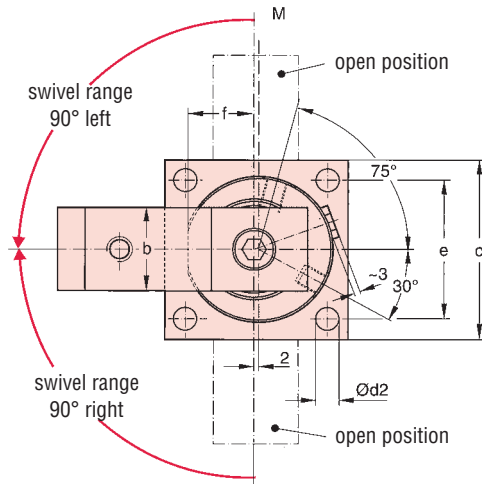

Symbol

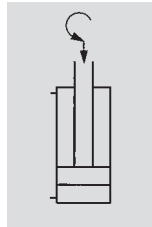

clamping force characteristics

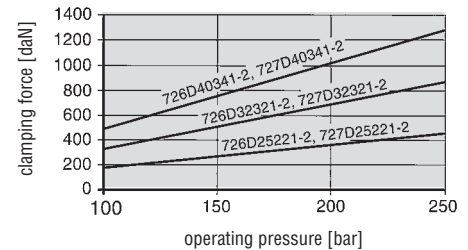

Model no.		Clamping force at 100 bar [daN]	Complete stroke S [mm]	Swivel stroke S1 [mm]	Clamping stroke S2 [mm]	Operating pressure		Oil consumption forward stroke [cm³]	Oil consumption back-stroke [cm³]	Piston Ø [mm]	Piston rod Ød1 [mm]	Con-nection G 4x	a	b	c	d2 Ø	e
Swivel right	Swivel left					min. [bar]	max. [bar]										
726D25221-2	727D25221-2	190	27	17	10	100	250	6,4	13,3	25	18	1/8	25	25	65	9	50
726D32321-2	727D32321-2	340	31	20	11	100	250	13,2	24,9	32	22	1/8	30	30	70	9	56
726D40341-2	727D40341-2	500	34	22	12	100	250	21,8	42,7	40	28	1/8	40	40	85	11	65

Model no.		f	H	H1	h	h1	h2	h3	h4	h6	h7	l	l1	l2	M	M1	R	t	Max. torque [Nm]	Weight ~ [kg]
Swivel right	Swivel left																			
726D25221-2	727D25221-2	23	173	53	55	118	61	57	3	35,5	44,5	88	51	19,5	48x1,5	M12	29	12	30	1,85
726D32321-2	727D32321-2	27	199	61,5	64	135	70	65	3	46	57	97	57	19,5	52x1,5	M12	34	15	45	2,6
726D40341-2	727D40341-2	31	222	68	77	145	76	69	3	44	57	117	63	29	62x1,5	M12	44	18	80	3,5

Hydraulic swivel clamps, double action

Block version

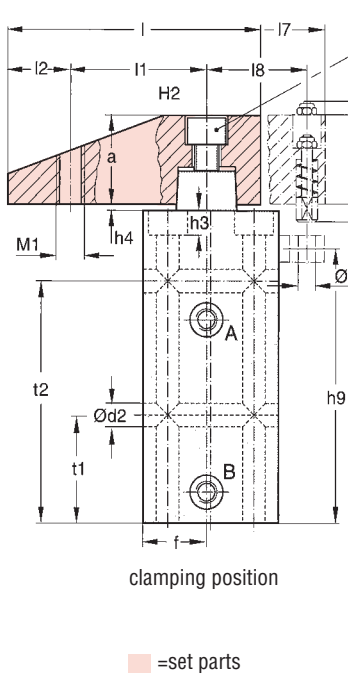

serial clamping arm screw fit to following models:
 726D25../727D25.. M10 x 20
 726D32../727D32.. M10 x 25
 726D40../727D40.. M12 x 35

Position control set
 (separate order)
 consisting of:
 1 special clamping arm, longer with spring-loaded thrust pad
 1 bracket for proximity switch (proximity switch not included in delivery)

order no. **793S01AS2-1**
 for model no. 726D25222-2, 727D25222-2
 order no. **793S02AS2-1**
 for model no. 726D32322-2, 727D32322-2
 order no. **793S03AS2-1**
 for model no. 726D40342-2, 727D40342-2

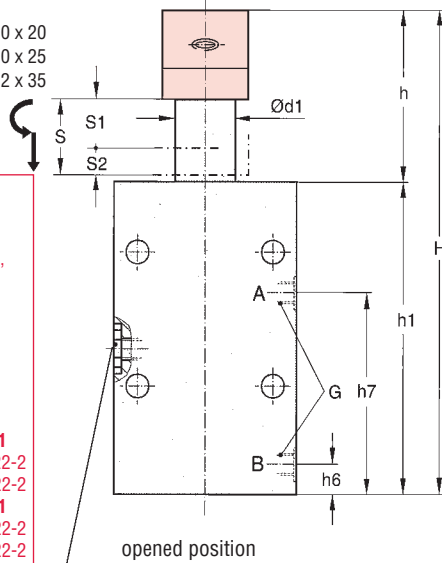

S = complete stroke
 S1 = swivel stroke
 S2 = clamping stroke

■ = set parts

Change of swivel direction

The swivel clamp can be adjusted as follows:

- Swivel stroke left
- Swivel stroke right
- Linear stroke

Notes on assembling the clamping arm

When loosening and tightening the clamping arm screw the clamping arm must be fixed to prevent damage to the piston guide. See table for max. torque for arm screw.

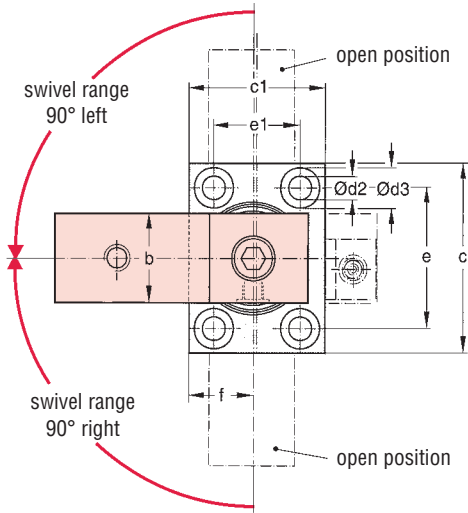

Symbol

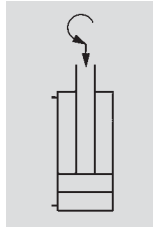

Clamping force characteristics

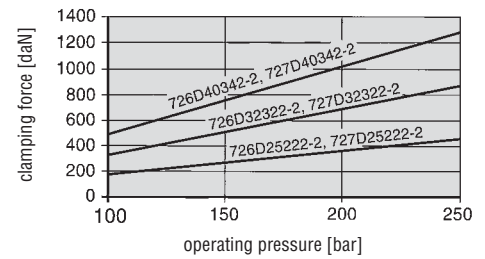

Model no.		Clamping force at 100 bar [daN]	Complete stroke S [mm]	Swivel stroke S1 [mm]	Clamping stroke S2 [mm]	Operating pressure		Oil consumption forward stroke [cm³]	Oil consumption back-stroke [cm³]	Piston Ø [mm]	Piston rod Ød1 [mm]	Con-nection G 2x	a	b	c	c1	d2 Ø	d3 Ø	e
Swivel right	Swivel left					min. [bar]	max. [bar]												
726D25222-2	727D25222-2	190	27	17	10	100	250	6,4	13,3	25	18	1/8	25	25	65	45	8,5	13,5	50
726D32322-2	727D32322-2	340	31	20	11	100	250	13,2	24,9	32	22	1/8	30	30	75	55	10,5	18	55
726D40342-2	727D40342-2	500	34	22	12	100	250	21,8	42,7	40	28	1/8	40	40	85	63	10,5	18	63

Model no.		e1	f	H	h	h1	h3	h4	h6	h7	h9	l	l1	l2	l7	l8	M1	t1	t2	Max. torque [Nm]	Weight ~ [kg]
Swivel right	Swivel left																				
726D25222-2	727D25222-2	30	20,5	165	55	110	9	3	10	70,5	93	88	51	19,5	28,5	37,5	M12	35	85	30	2,2
726D32322-2	727D32322-2	35	25,5	194	64	130	11	3	12,5	79	113	97	57	19,5	30,5	42,5	M12	45,5	100,5	45	3,5
726D40342-2	727D40342-2	40	29,5	217	77	140	11	3	14	91	123	117	63	29	30	46,5	M12	48,5	108,5	80	4,9

Safe connection

The adaptors were developed to ensure a safe connection between your own manufactured clamping arms and the piston rods of the swivel clamping cylinder.

Important note

Please ensure that the distance of the clamping point of your own manufactured clamping arm is identical with the dimension I1 in the tables on the pages 24.2 and 24.3. If dimension I1 is increased, the operating pressure must be reduced in accordance with the diagrams shown below.

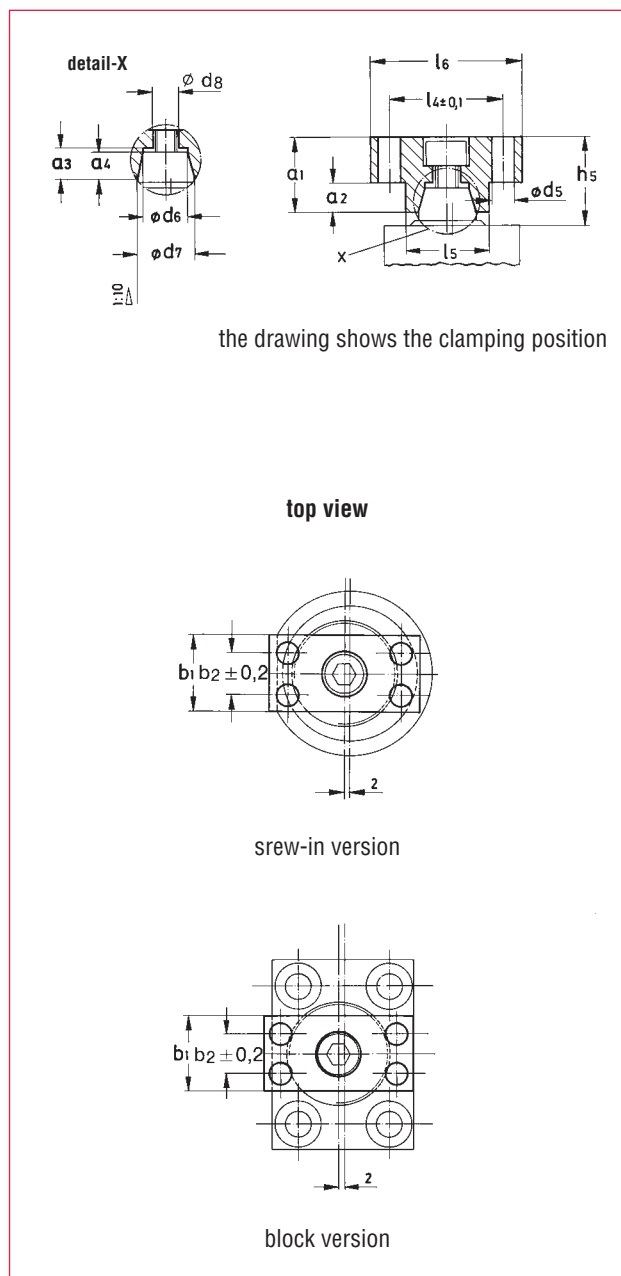

Clamping arm length-pressure diagram

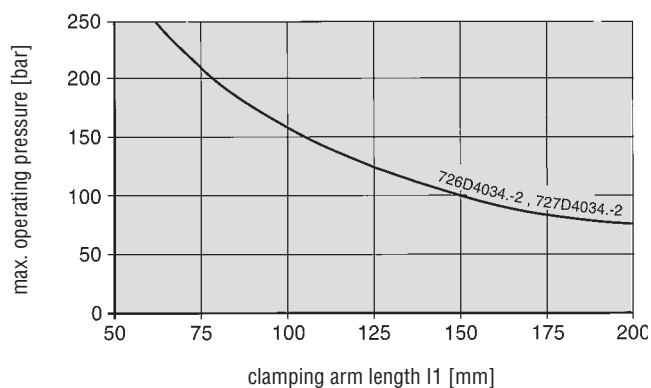
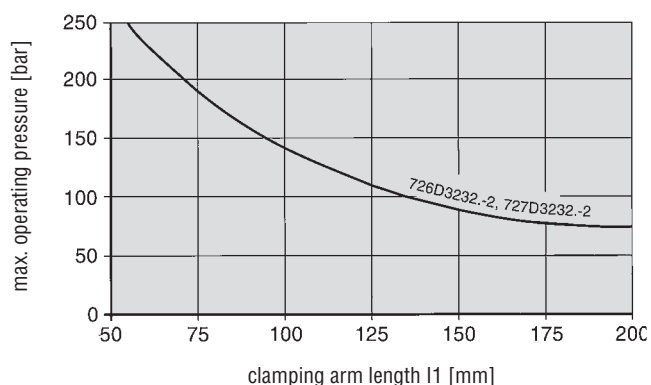
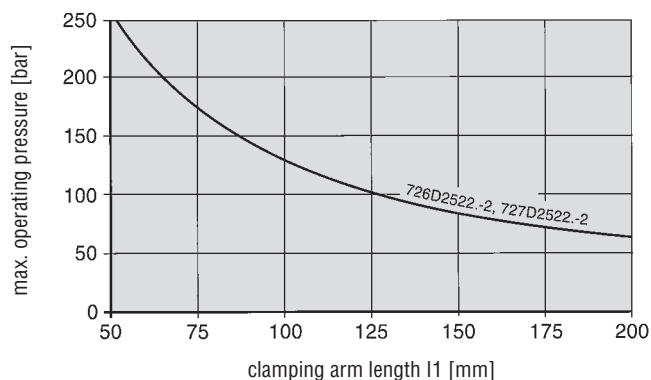

order no.	a1	a2	a3	a4	b1	b2	Ød5	Ød6	Ød7	Ød8	h5	l4	l5	l6	permitted max. clamping arm weight [kg]
728Z25ADO-1	25	12	11,5	10	25	14	5,5	17	18	11	28	45	30	60	0,3
728Z32ADO-1	30	15	12	10	30	16	9	21	22	11	33	46	30	60	0,5
728Z40ADO-1	40	20	17	15	40	20	9	26,5	28	13	43	60	40	80	1,1

Hydraulic retracting clamp, double action

Max. operating pressure 250 bar

Hydraulic retracting clamps are designed for clamping on machines and fixtures, for holding-down plates or to work as latch clamps as for example on foam ejection moulds.

In order to clamp, the clamping claw moves out of the clamp's body (23,5 mm), presses onto the workpiece while moving downwards (max. 9 mm). In the released position, the clamping claw is completely retracted.

Technical characteristics

- Precise guidance of the piston and the piston rod
- Hardened clamping surface of the clamping claw
- Dirt wipe-off stripper on the upper and lower side of the clamping claw
- Slim design
- High clamping force
- Workpiece tolerances are automatically compensated during the vertical clamping stroke
- end position control (standart equipment for 70622-DA)

Recommended accessories (separate order)

- 2 straight srew connections order no. D8S-R1/4
- connector order no. 8EL-002-1 (for 70622-DA)
- Sensing kit order no. 70622-DE (for 70622-D1)

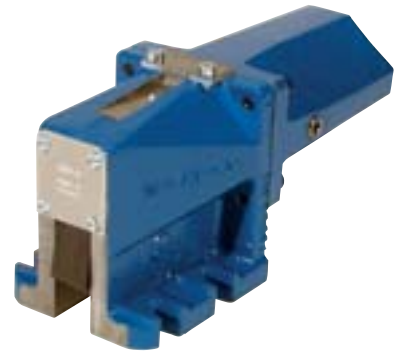

Symbol

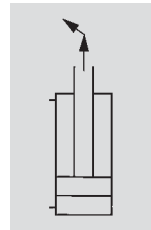

double action

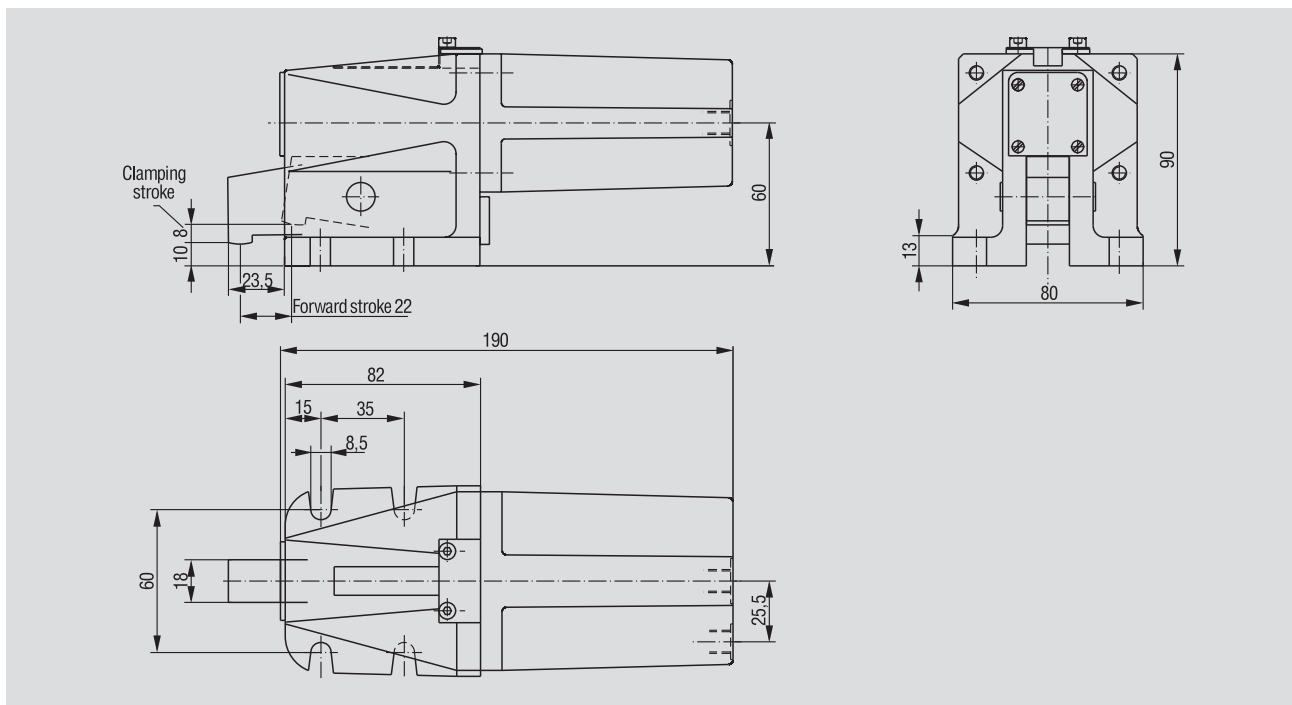

Model no.	Clamping force at 100 bar [daN]	Forward stroke [mm]	Clamping stroke max. [mm]	Operating pressure max. [bar]	Oil consumption/stroke forward stroke [cm³]	Oil consumption/stroke backstroke [cm³]	Connection G	Weight ~ [kg]
70622-D1 70622-DA	650	22	9	250	38	23	2xG1/8	4,1

Max. operating pressure 250 bar

These power clamps are used where a high clamping force is needed combined with small clamp dimensions. The clamps are equipped with double oil connections for the clamping and opening procedures. This makes it easy to connect pipes when the clamps are arranged close together

If necessary, the cylinder body (after removal of the fastening screws) can be turned 90° in relation to the clamp. The stated clamping force of 500 daN at 100 bar oil pressure is achieved only within the last 4 mm of clamping arm movement.

Technical characteristics

- Short clamping cycles with the double action version
- High clamping force with small dimensions
- Tolerance compensation of up to 4 mm

Recommended accessories (separate order)

The following screw connections are necessary to connect the clamp to hydraulic tubes and pipes:

1 or 2 straight screw connections, order no. **D8S-R1/8**

See pages 25.7 to 25.10 for all screw connections.



Symbol

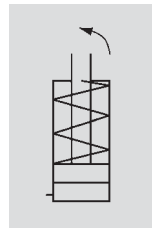

single action

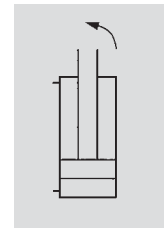

double action

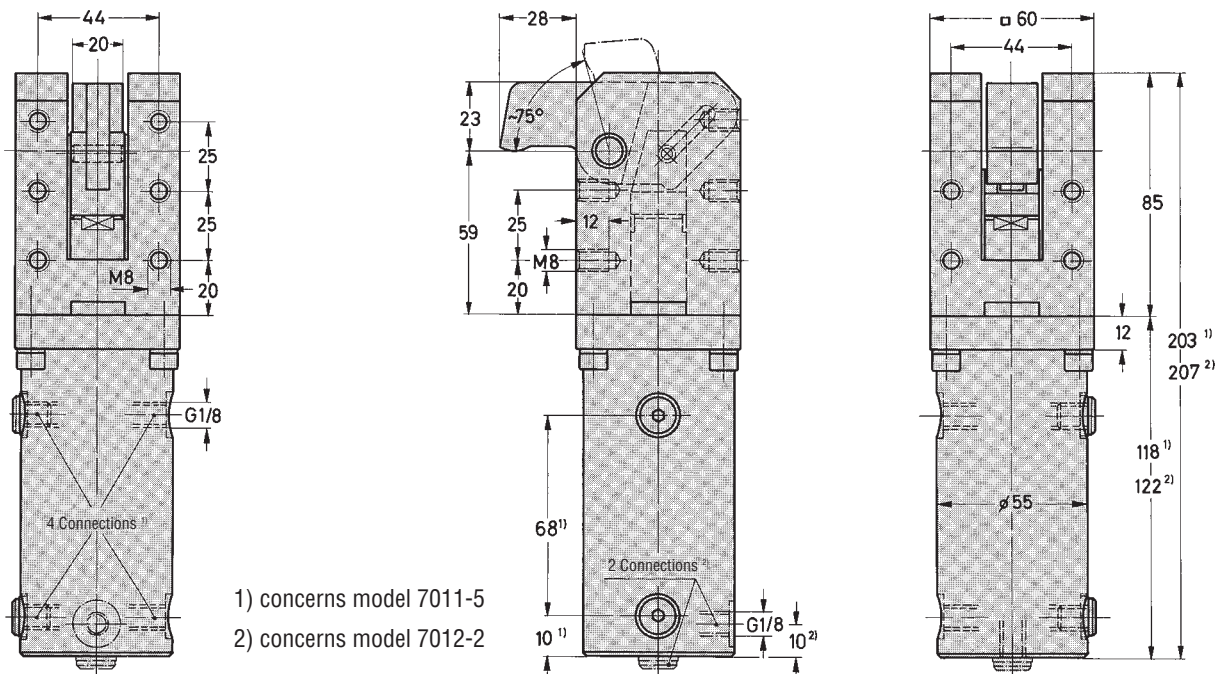

Model no.		Clamping force at 100 bar [daN]	Operating pressure max. [bar]	Oil consumption		Connection G	Weight ~ [kg]
single action	double action			forward stroke [cm ³]	backstroke [cm ³]		
-	7011-5	500	250	25,7	15,5	4xG1/8	3,8
7012-2	-	500	250	25,7	-	2xG1/8	3,9

Hydraulic edge clamp, single action

Max. operating pressure 500 bar

Edge clamps are mainly used where workpiece clamping "from the top" is difficult or impossible.

Its small design is an advantage where space is limited. The clamp is equipped with 2 hydraulic connections. Both connections are linked via a transverse hole. This allows the possibility to link the edge clamps directly if several clamps are to be operated simultaneously.

Technical characteristics:

- Spring retraction
- Clamping lever with or without ball element
- The hold down force is the vertically (downward) acting component of the clamping force

Recommended accessories (separate order)

The following screw connections are necessary to connect the clamp to hydraulic tubes and pipes:

1 straight screw connection, order no. **D8S-R1/4**

See pages 25.7 to 25.10 for all screw connections.



without ball element,
model no. **733E03701-1**



with a corrugated ball element,
model no. **733E03702-1**

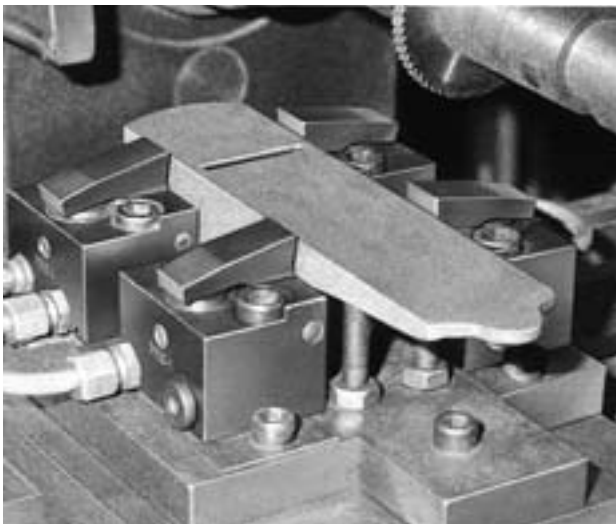

hydraulic edge clamp, single action, to clamp the bottom of planes in a milling jig

Symbol

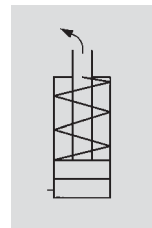

Model no.	Clamping force		Piston Ø [mm]	Max. clamping range		Max. operating pressure [bar]	Oil consumption stroke [cm³]	Weight ~ [kg]
	at 100 bar [daN]	at 500 bar [daN]		horizontal [mm]	vertical [mm]			
733E03701-1	370	1850	20	7	5	500	2,2	1
733E03702-1	370	1850	20	7	5	500	2,2	1

model no. 733E03701-1

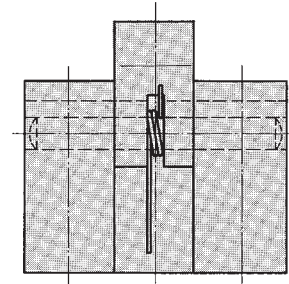
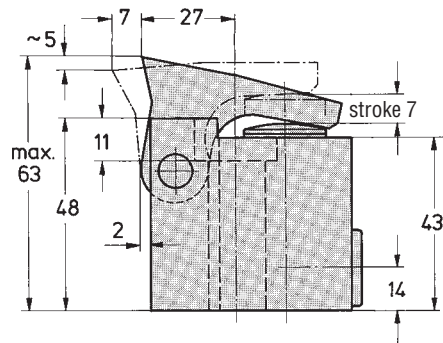

Note:
the distance between the mounting holes is 50 mm

model no. 733E03702-1

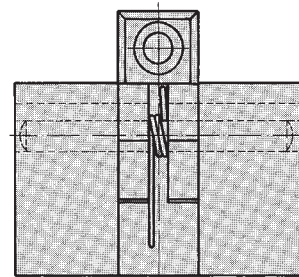
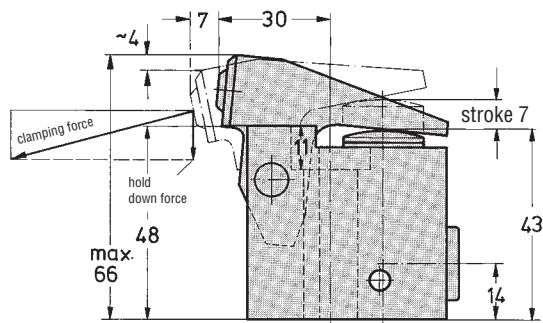

Note:
the distance between the mounting holes is 50 mm